

Value Proposition for Data Centers

Collocation or a trend of hosting customers' servers at a provider's physical location has been steadily growing in the recent years due to its many benefits. The collocation started primarily for hosting and managing web services. However, over the last decade, the term has expanded to mean much more than website hosting, including hosting customer's critical non-web related data, storage services, disaster recovery, and managed services all from one location.

Although, the dotcom boom and the general slow down in the worldwide economy has effected the collocation industry the same as others, the 2009 forecast still remains positive for data centers going forwards with their infrastructure plans. According to the research conducted by Tier1Research, an online technology research company, the demand for collocation services still outweighs the supply. If we look at percentages, demand for collocation services is still growing at a rate in two digit numbers which is explained by the mission critical nature of the data hosted at the collocation sites.

So why do companies continue to choose to collocate their data? According to a survey conducted by Hosting.com in August 2008, 67% of companies choose to collocate their data infrastructure to "improve availability and reliability," 49% do so to improve performance, and 45% to lower or eliminate cost. Furthermore, 69% of those surveyed expected ROI on their investment within 24 months, 24% of which expected returns within 6 months period. Additionally, 67% of the companies surveyed agree that if their servers were "down" (unavailable) for a period of just 24 hours, the impact on their business would be catastrophic.

Therefore, many companies rely on the data centers for not only hosting their data but also providing secondary backup sites and disaster recovery (DR) options. The survey was conducted over multiple industries ranging from financial services, retail, healthcare, IT providers, marketing and advertising firms, non-profits and city governments, etc.

In order to understand where data centers need to improve in order to stay ahead of economy, one must look at factors that companies feel are important when choosing their collocation provider. As the research by Hosting.com revealed, the seven most important factors while evaluating a data center are as follows in their order of importance: bandwidth (the most important), security, redundancy, power, DR options, expansion and monitoring. Additionally, while not critical, managed services provided by the collocation provider is viewed as an important value-add service by the majority of respondents.

PacketLight's Value Proposition to Data Centers

PacketLight's compact 1U WDM solutions are ideal for data centers to meet the customer demands placed on their services. With PacketLight's mix of various products, data centers have a cost effective way to ensure that all seven evaluation factors are met and exceed customer expectations.

- **Bandwidth**

As the type and size of companies choosing collocation services vary drastically, so do their needs for bandwidth requirements. Therefore, data centers must be equipped to meet the needs of a small business that needs 1GbE connectivity, as well as a multinational corporate with needs of 10Gbps connectivity. At the same time, data centers must provide this mix of bandwidth connectivity at affordable prices to make it attractive to the customer.

With PacketLight's Wave Division Multiplexing (WDM) equipment, data centers can virtually multiply their existing fiber backbone infrastructures either through CWDM (Coarse Wave Division Multiplexing) or DWDM (Dense Wave Division Multiplexing) technologies. PacketLight's CWDM systems

provide up to 8 or 16 wavelengths, or throughput channels. Each CWDM wavelength supports up to 2.5Gbps and can be expanded to 4.25Gbps support. This transfer rate is sufficient to support 1GbE Fast Ethernet or 1/2/4G FC, STM-1/STM-4/STM-16, and other protocols. An example of this equipment is well demonstrated by PL-400 by PacketLight Networks - please see <http://www.packetlight.com>.

On the other hand, DWDM (Dense Wave Division Multiplexing) is a technology with much higher throughput capacity transferring data of 10G FC, 10GBE, and STM-64. PacketLight's 10G DWDM systems provide up to 32 wavelengths of mixed service types, and can transport to long distances with integrated amplifiers (EDFA) and dispersion compensators (DCM). Due to its more precise lasers, the DWDM technology is a more appropriate solution for large capacity data transport and connectivity over long distances. An example of this equipment is well demonstrated by PL-1000 by PacketLight Networks - please see <http://www.packetlight.com>.

By utilizing PacketLight's compact CWDM and DWDM solutions (PL-400 and PL-1000) or the mixture of thereof, data centers are able to transport from 2MB to up to 10GB of data over 32 different channels over the same fiber pair or a single fiber, thus providing the mixture of bandwidth required by their customers.

- **Security**

As PacketLight WDM products are designed to operate on the layer 1 of an optical network, typical software security concerns are eliminated. Furthermore, through WDM technology, each wavelength within the fiber is independent and is protected without interlapping, thus ensuring the integrity of each customer's information. Furthermore, the operating systems of all PacketLight products are based on VxWorks, a highly secure programming language frequently used by NASA scientists. Additionally, the management portal of each unit is protected by multi-layer security structure and https encryption coding.

- **Redundancy**

PacketLight products provide ample protection and redundancy capabilities for all its products. Two optical facility protection methods are discussed below. The first, electrical switching, uses a cross connect to duplicate and select the working or protecting path, using two independent optics per each path and two sets of Mux/DeMux. The second option, optical switching, uses an optical switch to select the working or protected path.

Electrical Switching

In the first method each service is simultaneously transmitted/received to/from two dark fibers (see Figure 1). The service signal emanating from the left hand side device is transmitted to both working and protecting fibre. According to the optical power level of each wavelength, the service signal is delivered to the far end device.

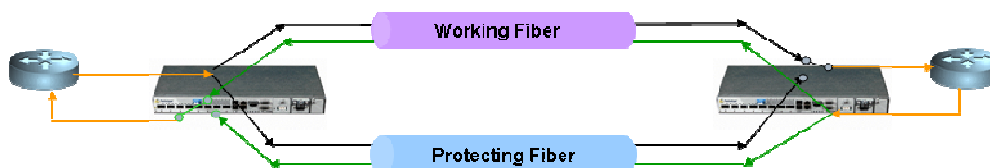

Figure 1

Figure 2 shows a more detailed diagram of how the cross connect duplicates (Tx) signals and selects the working and protecting path (Rx) for the receiving signal. The Tx signal is sent through the cross connect and duplicated through both transponders. On the Rx direction, the cross connect switches according to the receiving optical power of the transponder.

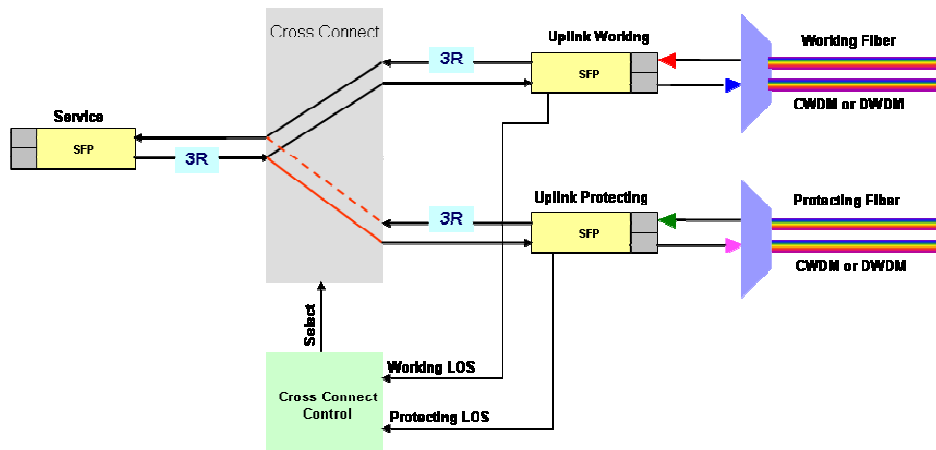

Figure 2

Optical Switching

In this method an optical switch is responsible for duplicating the data to the working and protecting fibre with an optical splitter, and selecting the operating fibre according to the optical power signals of all the services. (See Figure 2)

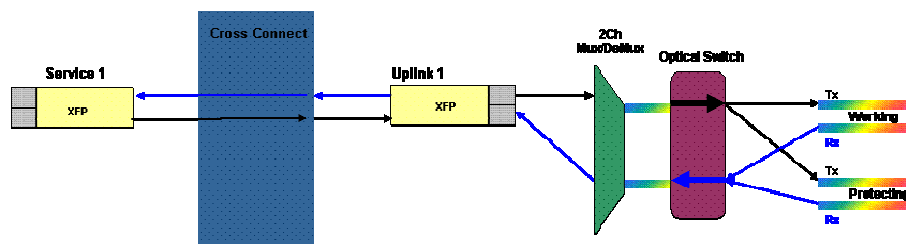

Figure 3

Each of the protection methods has its pros and cons based on the customer requirements which must be taken into consideration when designing the protection on the optical network.

- **Power**

All PacketLight units are designed to meet the power requirements of all data centers while keeping the electricity expense low for the providers. The units are supplied with two power supplies, AC and DC: 100-240V AC, -32-72V DC, 68Watts max, both working in an active and immediate failover mode. In addition, the power supplies can be a mixture of AC and DC, or all AC or DC, thus providing the redundancy to the data center specification.

- **DR Options**

PacketLight offers end-to-end Disaster Recovery Connectivity for Enterprises and SMBs. As the dependency of organizations on their digital data and the awareness to risks grows, data protection and data availability together with smooth 24/7 availability has become a major concern for IT managers. This is complemented by the need to comply with new regulation world-wide which requires setting up remote Disaster Recovery (DR) sites.

Enterprises and SMBs are searching for ways to implement remote backups in a simple and low-cost manner, either by themselves, or with the help of their data centers or service providers (SSP). This trend by the Enterprises and SMBs has triggered many providers to realize that offering SAN connectivity to their customers is a great way to generate more revenues from their existing infrastructure (hosting or by providing services).

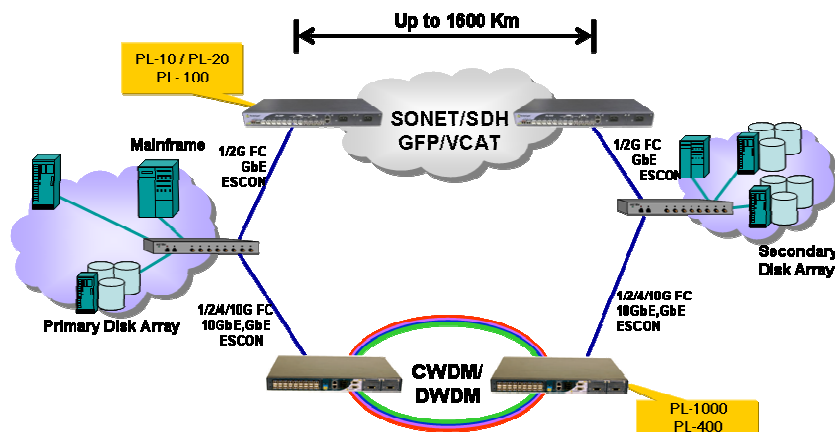

PacketLight's products are designed for enabling both data centers and the Enterprises to achieve their DRP and BC goals, provide all the needed functionality in a compact 1U chassis at a competitive cost, carrier grade with protection and performance monitoring capabilities, easy to install, use and maintain.

• **Expansion**

PacketLight's pay-as-you-grow architecture gives flexibility and scalability to data centers that allows them to keep low initial cost and scale as their customer needs grow. The PL-300 is PacketLight's foundation for Multi chassis application architecture. With the PL-300 a customer can start with a low cost solution that meets urgent needs and grow step by step to form a full 32 wavelength solution over a single or dual fiber as demand expands.

The PL-300 family of products extends PacketLight's optical network solution capabilities by providing a wide range of passive optical modules. The PL-300 functionality provides the needed optical layer functions of an Arrayed Wavelength Grating (AWG) Mux/Demux, 32 DWDM wavelength Multiplexing, Optical Dispersion Compensation module (DCM), Optional Add and Drop (OADMs) interleaves, splitter and combiners.

The PL-300 interconnects seamlessly with PacketLight's WDM 10G and Sub-10G products and third party WDM products, to form cost effective high capacity DWDM and CWDM solutions. The PL-300 provides low granularity wavelengths, add and drop capabilities and is used to increase 4G and 10G solution reach.

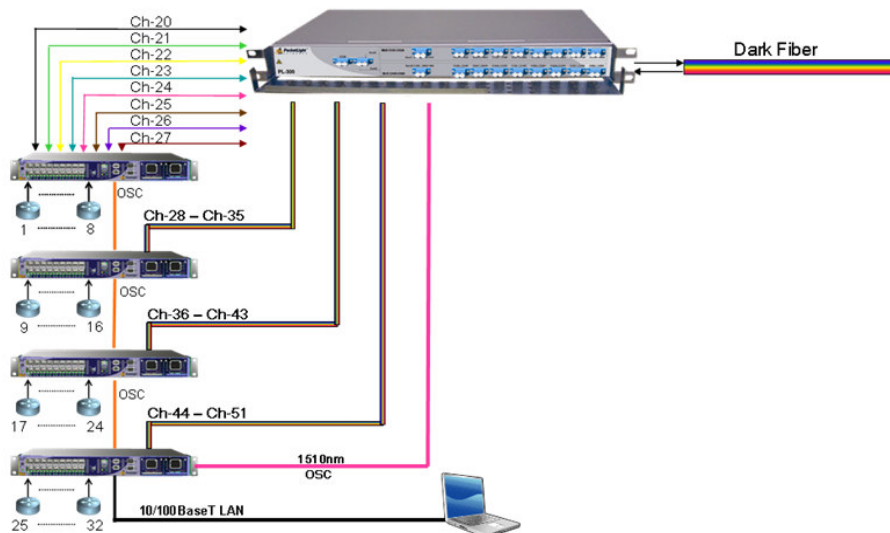

www.packetlight.com

With PL-300 expansion capabilities, data centers can grow based on their customer needs and requirements while maintaining a steady investment cost.

- **Monitoring**

PacketLight offers multiple monitoring capabilities to customers as well as data centers. First and foremost, PacketLight's own GUI based system is easy to use and allows users to configure and monitor each port on the system independently. Furthermore, each unit is manageable remotely via a dedicated optical supervisory channel (OSC) giving the users ability to maintain and monitor all units from one location. Additionally, each unit can be integrated into an already existing EMS or NMS software via SNMP. Currently, PacketLight is fully integrated with such EMS systems as RADview and common third party SNMP tools such as IBM Tivoli, HP Openview, SNMPc etc.

Summary

The nature of data centers has evolved tremendously since the early 90's. Our dependence on the data centers today is far deeper than even in near past of 1999. Most data centers are fully occupied with mission critical servers and data. Therefore, data centers themselves are faced with unique challenges in meeting their customer standards for ensuring the integrity and availability of the data they store.

PacketLight products can assist data centers achieve all 7 major requirements chosen by customers as the most important factors in choosing data centers: **Bandwidth, security, redundancy, power, DR options, expansion and monitoring.** PacketLight's compact 1U solutions allows the data centers to offer a mixture of bandwidth to its customers ranging from as low as 2MB up to 10G at pay-as-you-grow architecture. With multilevel security access and innate level 1 security of optical networks, data centers are protected from compromising. Additionally, PacketLight gives multiple options to data centers for ensuring the proper redundancy of the equipment. Furthermore, dual AC or DC power supply blocks allow the data centers low power consumption while having the necessary redundancy. With PacketLight's passive PL-300, data centers have a truly scalable solution that can be expanded at customer request with minimal additional hardware and without high software licensing fees. Finally, the imbedded user friendly GUI allows easy configuration and monitoring, while still allowing the use of third party monitoring software through SNMP.

About PacketLight Networks, Ltd.

PacketLight Networks offers a suite of Leading 1U Metro CWDM and DWDM solutions, for transport of data, voice and video applications, over dark fiber and WDM networks, featuring high quality, reliability and performance at affordable prices. Our products are distinguished with low power consumption ideal for CLE (Customer Located Equipment) allowing maximum flexibility as well as ease of maintenance and operation and providing real Pay-as-you-grow architecture. PacketLight customers are carriers, service providers, data centers, IT integrators and enterprises who are active in meeting the demands for metro Ethernet, business continuity, Triple Play solutions and enterprise data sharing applications. For product and reseller information, Please contact info@packetlight.com